

VH928 User Manual

Toilet Cubicle User Guide & Spare Parts

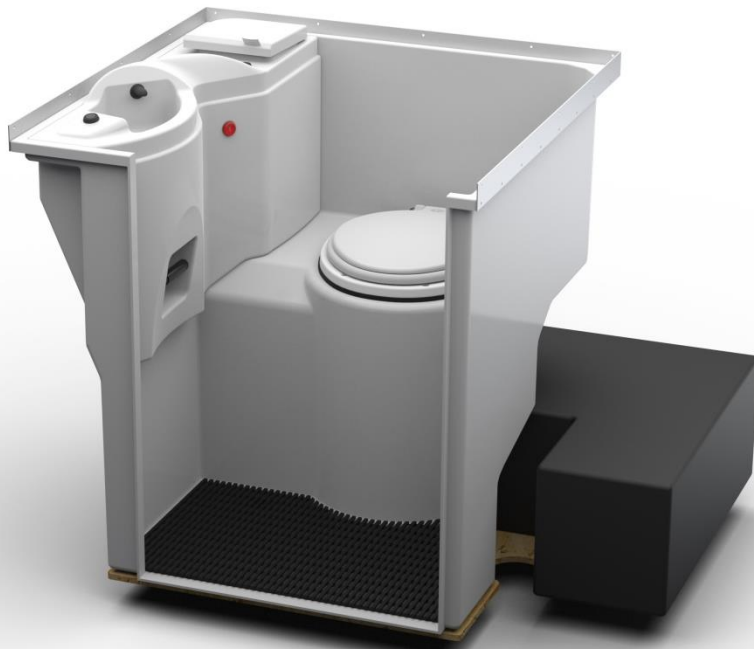

Freshwater Flush & Recirculating

Table of Contents

Title	Page
Introduction	3-4
Cubicle Operation	5-6
Cleaning & Hygiene	7
Maintenance	8-10
Warranty Claims	11
Spare Part Lists	12-20
Cubicle Electrics	21-23
Fault Finding	24-29
Service	30-36

Introduction

- Hydroflush

The Shades Hydroflush system uses a pre-set quantity of fresh water dispensed via a high pressure pump. Using a maximum of 500ml on a timed cycle that also controls an inline solenoid and slide valve fitted to the bottom of the bowl. A small quantity of clean water should remain in the bowl to seal the slide valve and prevent odour returning into the cubicle. For consistent operation of this valve the maintenance guidelines must be followed, using the correct toilet paper and chemical will prolong the life of the system.

The Shades system will either have a single supply tank for both hand wash and flush or individual tanks. All tanks will be controlled by level sensors to protect the system electrically which is controlled by a PIR sensor that comes on when entering the cubicle. The system will not work unless the PIR has been activated.

- System Schematic

Below shows a typical system layout of the freshwater system.

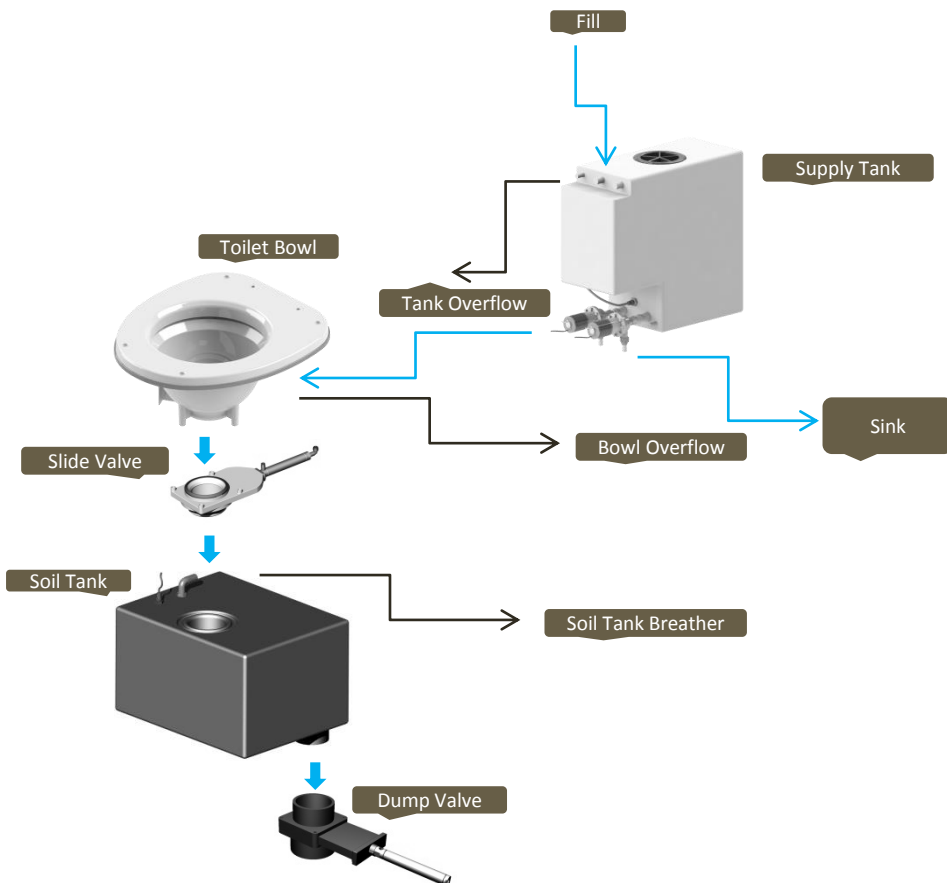

Introduction

- Recirculating System

The Shades recirculating system requires the soil tank be filled with a 'charge' of freshwater via the hose connector. A light will show when the system is sufficiently primed and water can then recirculate through the bowl via the high pressure pump. Using a timed cycle that also controls the slide valve fitted to the bottom of the bowl the flush cycle can be activated as many times as possible without the risk of wasting water. A small quantity of water should remain in the bowl to seal the slide valve so it is important to add chemical to the system to remove bad odours. For consistent operation of this valve the maintenance guidelines must be followed, using the correct toilet paper and chemical will prolong the life of the system.

This system will have a separate supply tank for the hand wash . All tanks will be controlled by level sensors to protect the system electrically which is controlled by a PIR sensor that comes on when entering the cubicle. The system will not work unless the PIR has been activated.

- System Schematic

Below shows a typical system layout of the freshwater system.

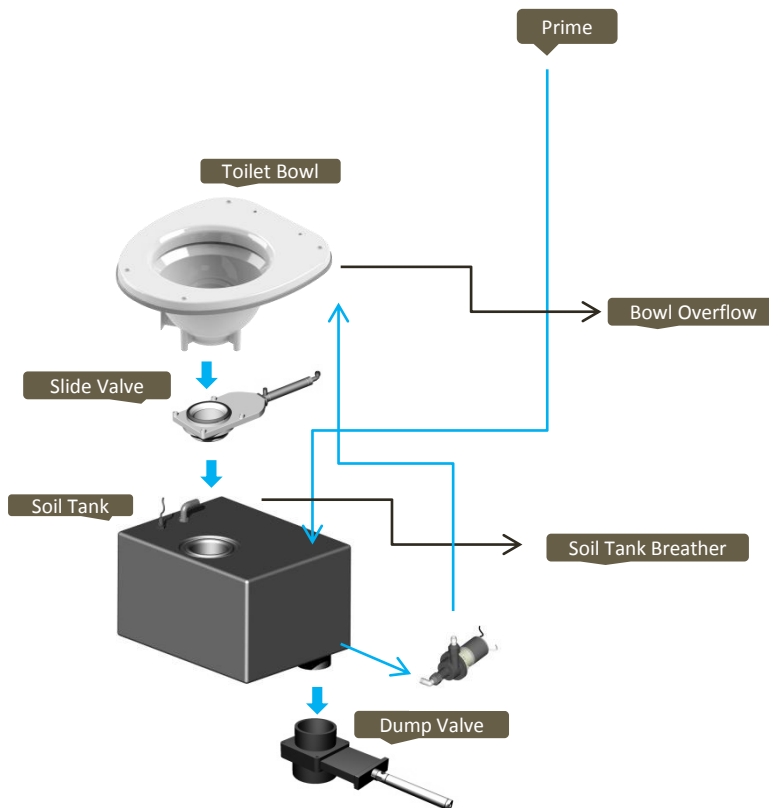



Cubicle Operation

- Switching the cubicle 'ON'

Engage the WC master switch on the dashboard. The cubicle interior lamps will turn on for 60 seconds and then switch off. The cubicle is now ready to use. (It is recommended that the vehicle engine is running to protect the batteries.)

- To Flush The Toilet

Push the flush button  once to flush the toilet with a set quantity of water. Should a further flush be required, wait for the flush cycle to complete then press the button again.

When the soil tank is full, the dashboard LED  will illuminate and the "Occupied" lamp will signal. The toilet is now out of use until the soil tank is emptied.

When the clean water tank is empty the dashboard LED  will illuminate and the "Occupied" lamp will signal. The toilet is now out of use until the water tank is re-filled.

- To Wash Your Hands

Depress the hand wash button  once to dispense a set amount of water.

When the hand wash tank is empty the dashboard LED  will illuminate to alert the driver.

- Cubicle Extractor Fan

The ventilator fan runs continuously when the master switch is ON but has the option to only work when the light is activated.

- Water Tank Filling & Emptying

Tanks are filled via the hose connectors located in the side locker. Each tank also has its own drain for cleaning or winterization.

Cubicle Operation

- Soil Tank Emptying

The evacuation valve on the soil tank is controlled pneumatically and can be opened by pulling a black knob located behind the fuel filler flap. The flap is locked using a T-key and the knob must be pushed back in to close the valve when finished.

- Smoke Alarm

The smoke alarm is mounted in the ceiling panel of the toilet and is powered via the main toilet control board and not a battery. It is also connected to a light on the dashboard which illuminates should the smoke alarm be activated.

- Vanity Pod

The vanity pod houses the soap, the hand-dryer, and the air freshener. The pod can be accessed using the key provided. You will need to access the pod to refill the soap dispenser and to fit new air freshener cartridges.

The air freshener should be fed by a separate power source to ensure that it works all of the time and not just when the cubicle is in use.

- In Case of Emergency

Depressing the RED alarm button inside the cubicle will alert the driver.

Cleaning & Hygiene

- Cubicle Cleaning

The cubicle is manufactured from Glass Reinforced Plastic (GRP) with high gloss interior and lightly textured exterior surfaces. This surface finish is delicate and must only be washed down using a mild detergent. The use of a caustic or abrasive material is not recommended, as this will affect the appearance.

- Toilet Bowl Cleaning

To protect the finish of the SS toilet bowl do not use abrasives of any kind. To clean the bowl, use a mild anti-bacterial detergent and suitable brush.

- Litter Bin

The cubicle features 5 litre plastic bin located next to the sink. The use of a bin liner is recommended.

- Air Freshener

The air freshener cartridges will need to be replaced every 60 or 90 days, depending on the dispensing setting you have selected. Replacements cartridges are available from Shades Technics.

Mandarin scent - Cat No. = 800064

Lavender scent - Cat No. = 800065

- Soap Dispenser

To fill the dispenser, push down on the top of the lid of the dispenser and pull the cover towards you. Fill with liquid soap.

- Toilet Roll

It is recommended that a high biodegradable paper is used at all times.

Cat No. = 800103 Pack of 36. (Available from Shades Technics)

Domestic grade toilet paper is not recommended as this can block the system.

Maintenance

- Daily Routine

Prior to the vehicle entering service the holding tank should be charged with an additive to sanitise the effluent.

The recommended product is **Shades Super Sani ECO** or **Sani RC**, formulated from natural essential oils, this formaldehyde-free formula is contained within a water soluble membrane. A single 16 gram sachet contains the recommended dosage for 110 litre capacity holding tank and will function for a maximum of three days.

To apply:

1. Ensure the soil tank is empty.
2. Check the tank evacuation valve is closed
3. Check the WC clean water tank is full.
4. Switch on power to the cubicle (see page 3)
5. Press the flush button and drop the complete sachet into the bowl.

Cat No. 800025 (Box 100) or **Cat No. 800026** (Carton 1000)

Caution: Do not open the sachet.

It is recommended that the WC supply tank is drained and the soil tank is emptied at the end of every day.

The freshwater tank should be emptied and re-filled daily. To help maintain a clean tank and the use of a sanitiser is recommended. Shades can supply a suitable product that disinfects the water, that is safe to drink and non-irritable to the skin and eyes. **Cat No. 800060**

Maintenance

- Weekly Routine

Check extractor fan function.

Inspect the security of the faucet, door hinges and toilet seat. Check the operation of the cubicle door and lock function.

Check electrical and plumbing connections for security and leaks.

Check water flow to the hand basin is smooth and constant.

- Quarterly Routine

Rinse soil tank using sprinkler system fitted to the soil tank by connecting a mains fed hose. Keep the valve open during rinse cycle.

Lubricate soil tank evacuation valve (to be carried out immediately after flushing through the soil tank). Undo the four fixing bolts holding the soil valve assembly together and remove the main body section. Lubricate the slide paddle using lithium grease or similar so the open/close operation is smooth. Replace the valve body and bolt together. Do not over tighten as this will restrict the operation of the valve.

Disinfect the hand wash tanks and flush through with clean water.

Check the air freshener cartridge, if the LED on the unit flashes every 3 seconds then the cartridge is empty and will need replacing. To energise the replacement cartridge, remove the tab from around the middle of the unit.

Maintenance

- Winterization

If the vehicle is to be parked in zero or sub-zero temperatures, it is imperative that all water containers are completely drained.

Note: No warranty claims will be accepted on any winter damaged parts.

- Jump starting

When jump starting the vehicle, please ensure that the dashboard master Switch for the WC is off!

- Fault Reporting

1. In the unlikely event of a fault occurring an emergency parts kit has been supplied along with the enclosed comprehensive fault analysis flow chart
2. Using these charts, determine the cause of the fault and replace the faulty item from the kit if possible.
3. To order a replacement kit or non-kit part contact the dealer as specified on the contents page (Page 2) of this manual, quoting the cubicle serial number. The serial number is located behind the vanity access panel.
4. In order for replacement goods to be dispatched a simple warranty procedure must be followed.

Note: Tampering, unauthorised involvement or preventable damage will result in a charge being levied

Warranty Claims

Shades Technics offer a comprehensive warranty cover for all products, valid for 12 months from the vehicle's date in service.

Warranty does not cover shipping costs.



Cubicle

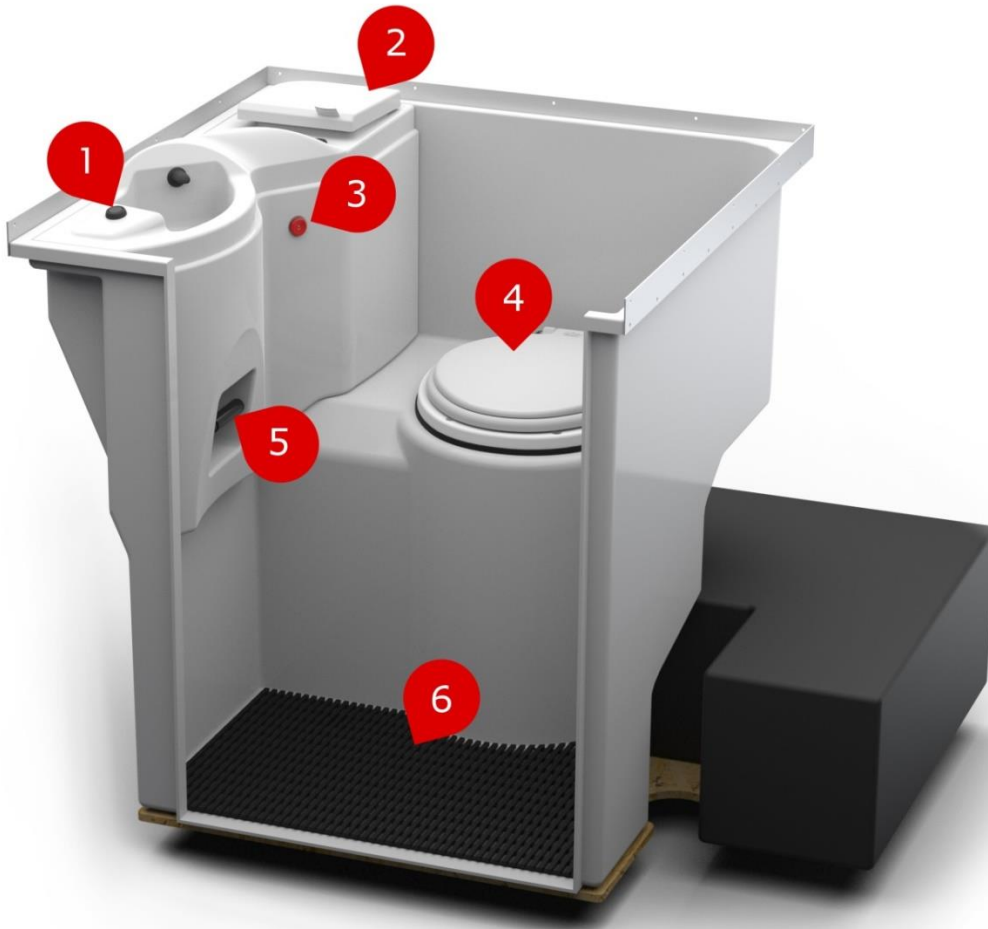

No.	Description	Part Number
1	Hand Wash Button	714007
2	5l Bin	661002
3	Alarm Button	714030
4	Toilet Bowl Assembly	See page 13
5	Toilet Paper Spindle	661618
6	Floor Mat	E928011

Cubicle Interior

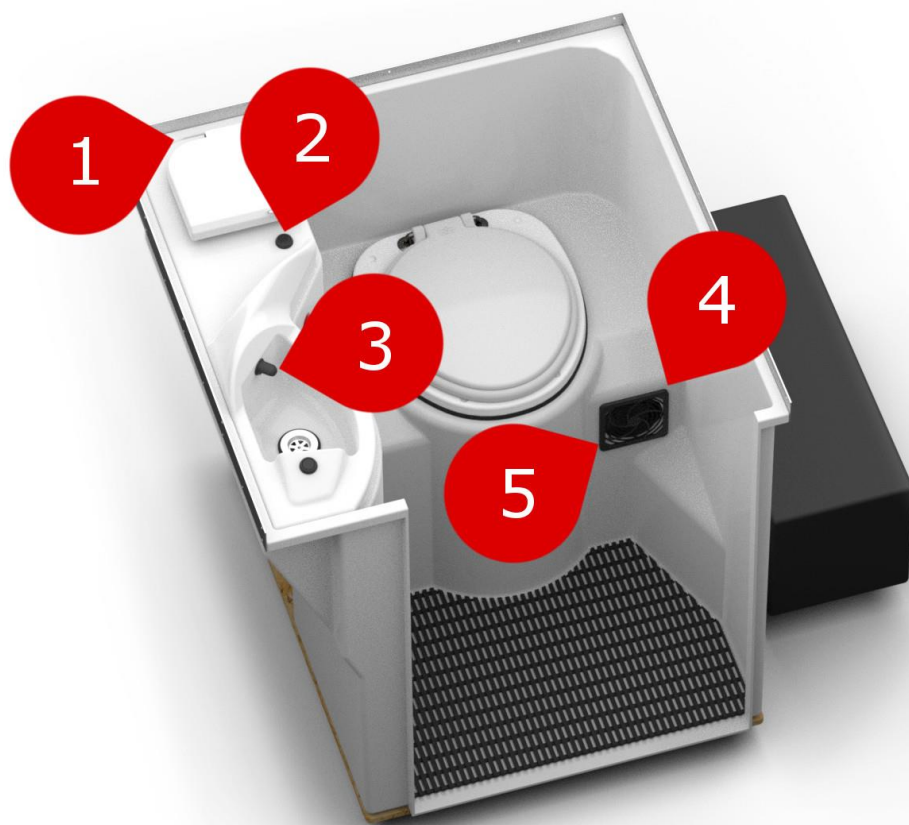

No.	Description	Part Number
1	Bin Hinge	661410
2	Flush Button	714007
3	Faucet	663609
4	Fan Grill	661501
5	Extractor Fan	727515

Bowl Kit



No.	Description	Part Number
1	Toilet seat	735100
2	Stainless Steel Bowl	731310
3	Seat Hinges	735102
4	Solenoid Valve (Freshwater system only)	714622
5	Slide Valve	735713

Vanity Pod

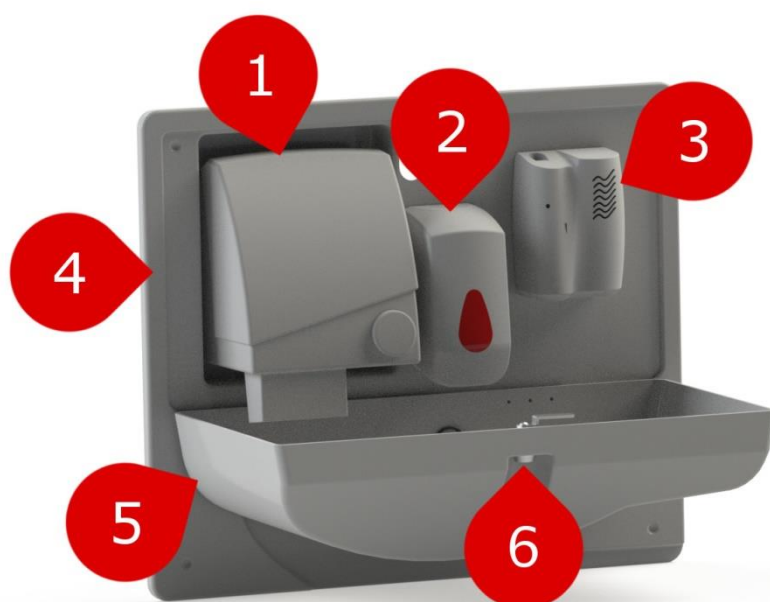

No.	Description	Part Number
1	Hand drier	661800
2	Soap Dispenser	661665
3	Air Freshener	714007
4	Vanity Backboard	688808
5	Vanity Pod Door Assembly	688806
6	Lock	800063

Soil Tank

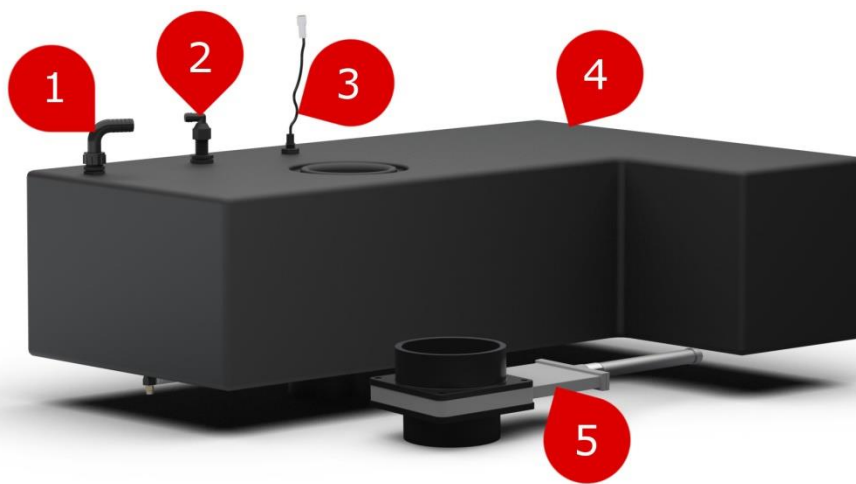

No.	Description	Part Number
1	Tank Breather	744022
2	Tank Sprinkler Assembly	733035
3	Float Switch	714502
4	Soil Tank (Freshwater)	H928022
4	Soil Tank (Recirculating)	H928122
5	Pneumatic Dump Valve	735774

Freshwater Tank

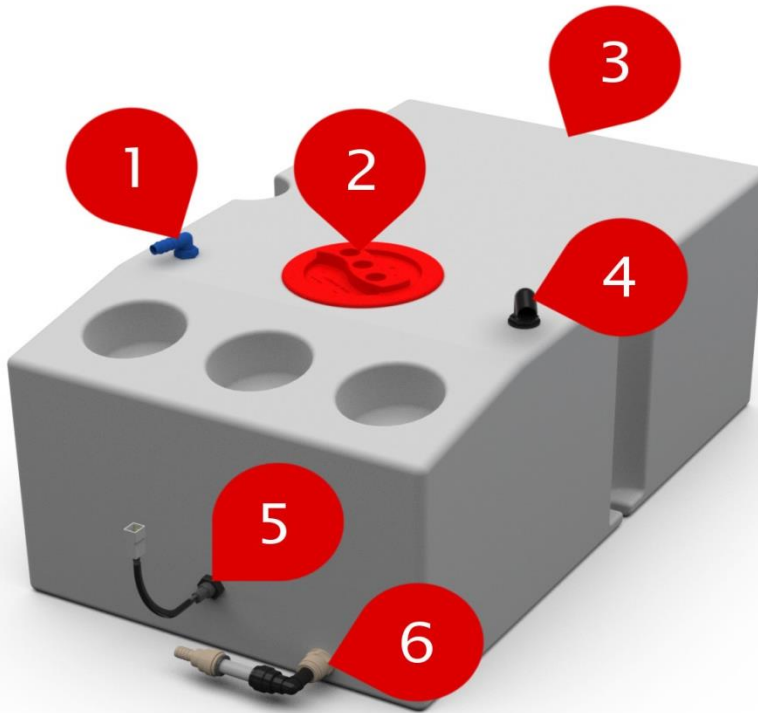

No.	Description	Part Number
1	Inlet	747032
2	Hatch Cover & Seal	732051
3	Freshwater Tank	H928021
4	Breather	744011
5	Float switch	714514
6	Outlet	747028

PCB with flush timer



No.	Description	Part Number
1	Flush Timer Module - (Freshwater Only)	730002
2	Isonic Valve	735714
3	PCB	730638
4	PIR	712035

Pump Plate

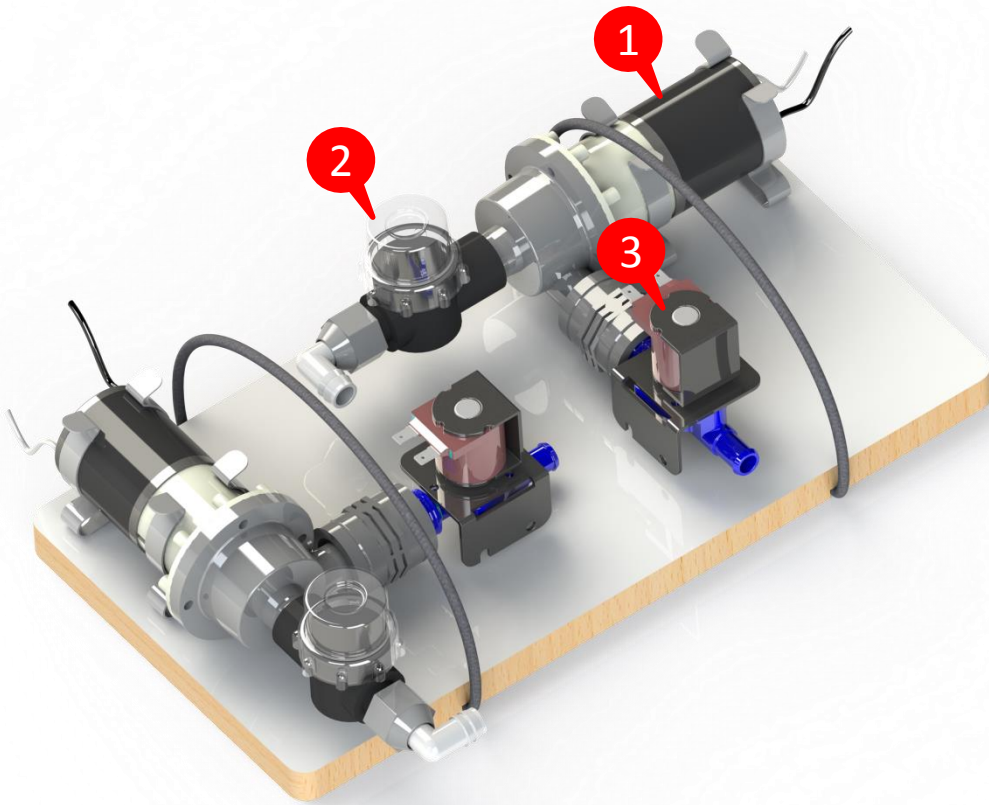

No.	Description	Part Number
1	HW Pump & Flush Pump	702110
2	Filter - (Freshwater Only)	722102
3	Solenoid Valve - (Freshwater Only)	714622

Symbols (stickers)

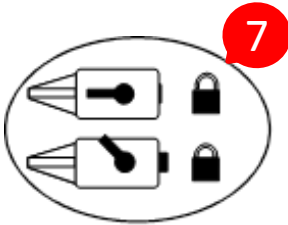
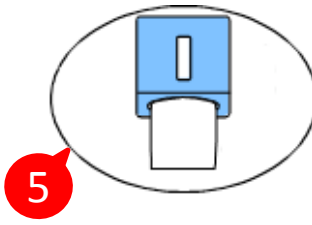
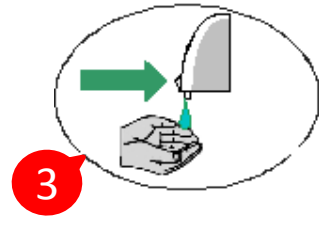
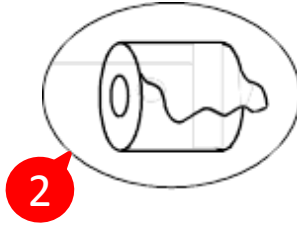
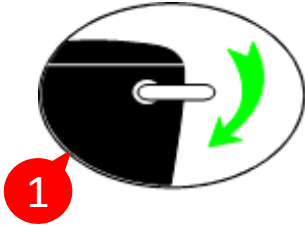

No.	Description	Part Number
1	Toilet Flush	VB735562
2	Toilet Paper	VB735569
3	Soap	VB733510
4	Trash Bin	VB735567
5	Paper Towel	VB735573
6	Do Not Stand	VB735560
7	Door Lock RH	VB735564
8	No Smoking	VB735563
9	Alarm Button	VB735566

Cubicle Electrics

- Description

The Toilet Cubicle Control Board is a solid state electronic control unit that manages all toilet cubicle functions. All output devices are short circuit and over-voltage protected for reliability and safety.

- Operation - Power-up & voltage low indicator

On power-up the control board enters the shut-down mode for 60 seconds. In shut-down mode, the occupied lamp will be on and all other outputs off.

After 60 seconds, provided that the voltage is not too low, the control board will enter the normal operating mode.

If at any time the voltage drops below the threshold (set by VR1) for more than 5 seconds, the control board will re-set. After a re-set, the board starts in the shut-down mode for another 60 seconds before being fully functional.

The threshold voltage is factory set to 22V, the RED 'low voltage' LED will begin to flash if the supply drops below the threshold.

The board also features a float switch override to bypass the float switches for fault finding.

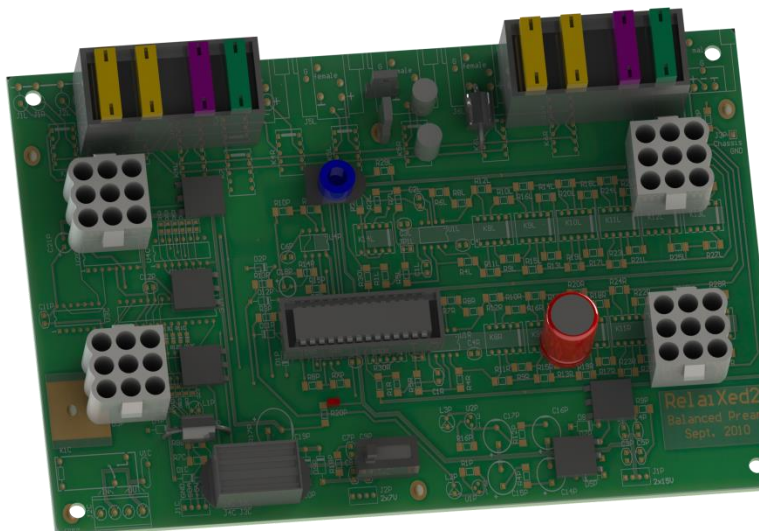

Cubicle Electrics

- Wiring diagram

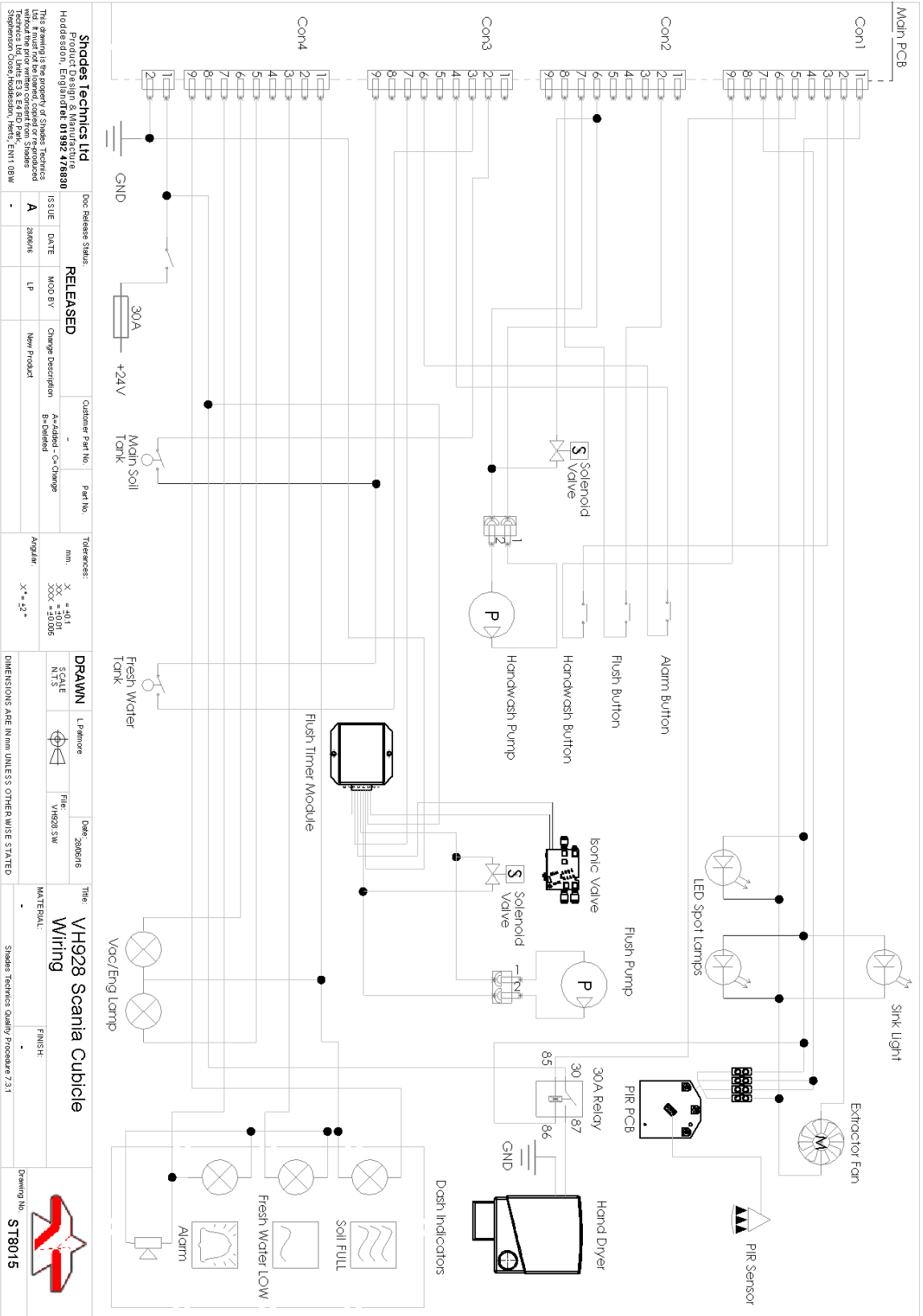

Fault Finding

- System Without Power
- Extractor Fan Not Working
- Alarm Button/Buzzer Not Working
- Repeated Flush
- Hand drier not working
- Bad odour from toilet
- WC Not Working
- Interior Lamp Timer
- Interior Lights Not Working

Fault Finding

- System Without Power

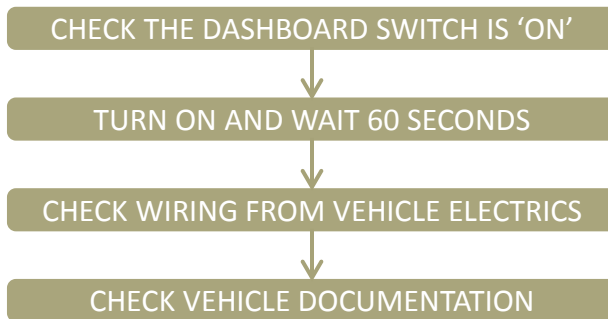

- Extractor Fan Not Working

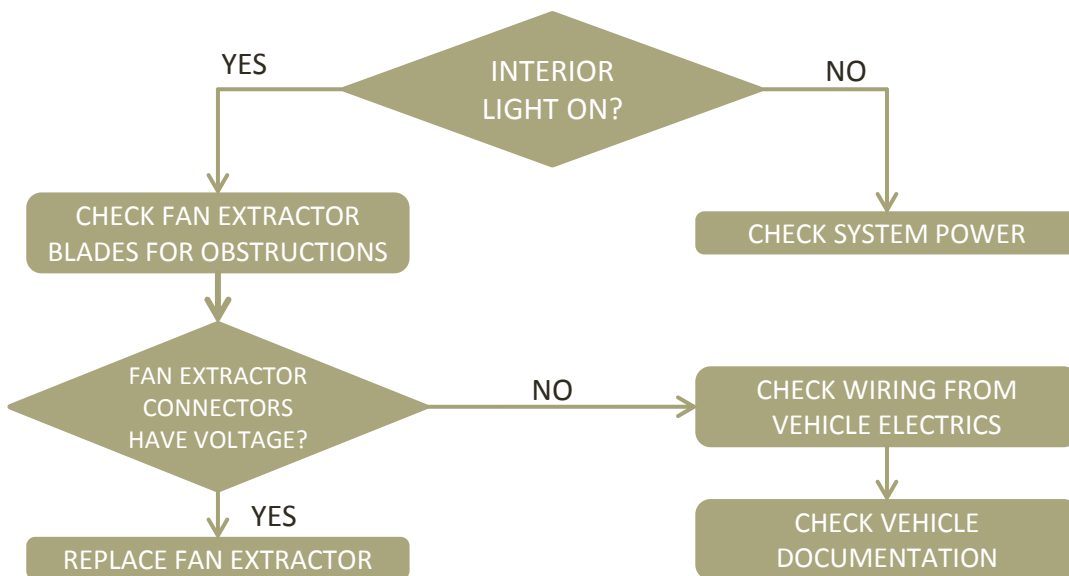

Fault Finding

- Alarm Button/Buzzer Not Working

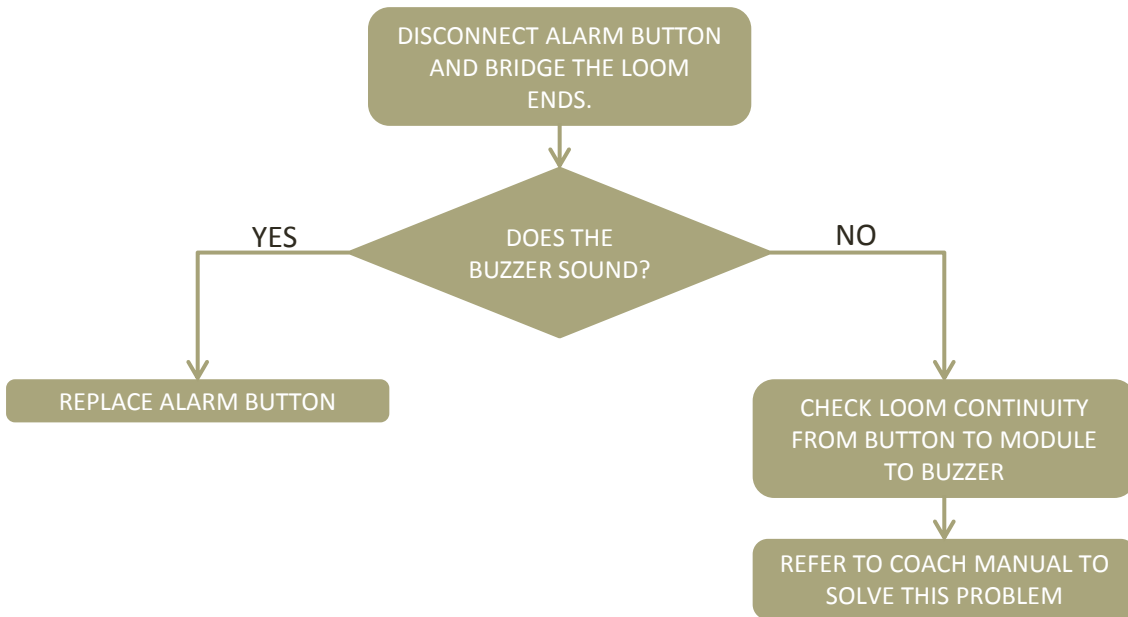

- Bad odour from toilet

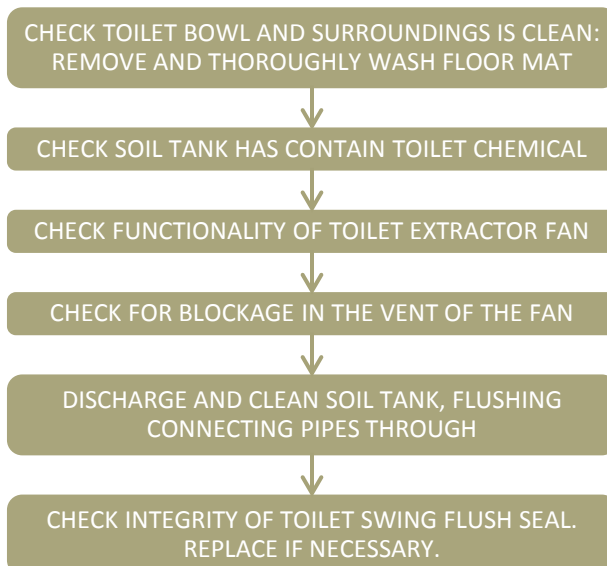

Fault Finding

- Repeated Flushing

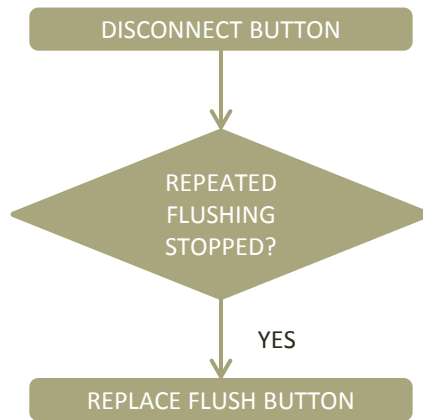

- Hand drier not working

The Aircalor Hand-Drier will only Function with the WC Master Switch On and the Cubicle Interior Light On.

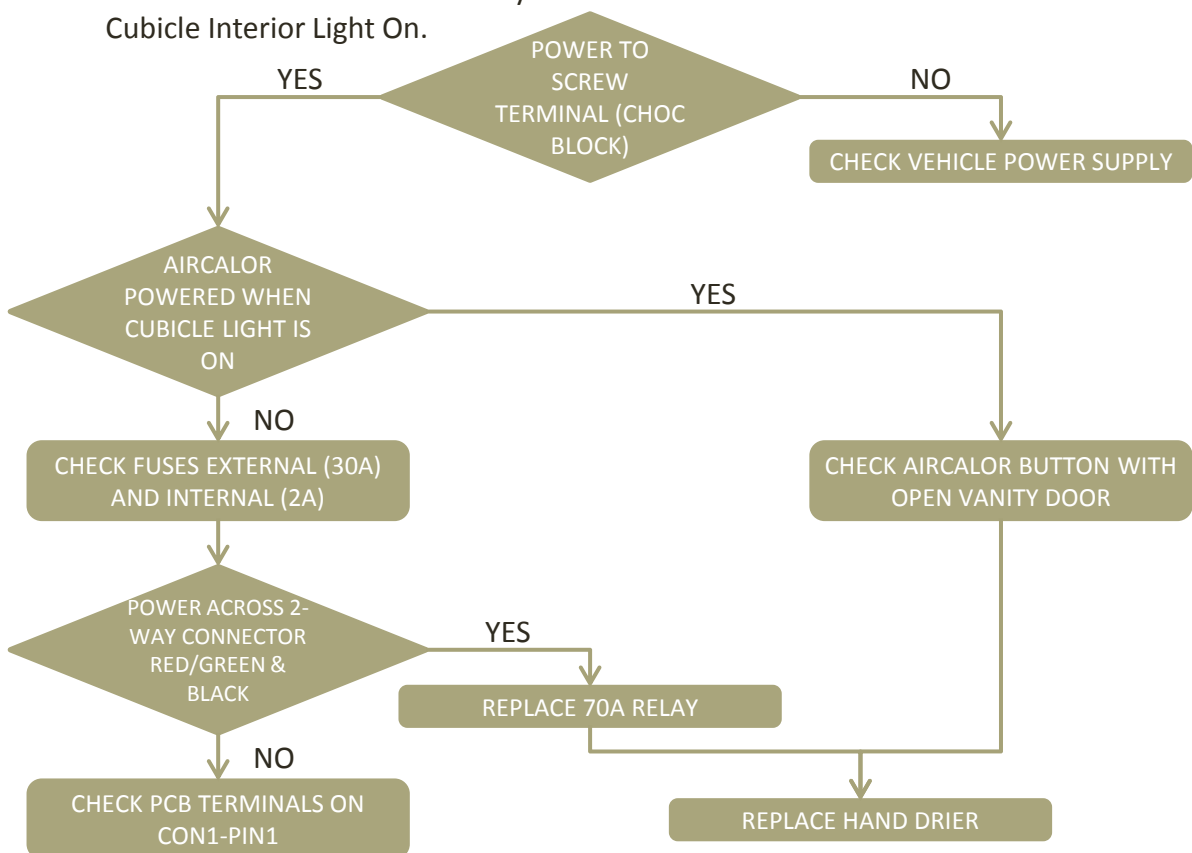

Fault Finding

- WC Not Working

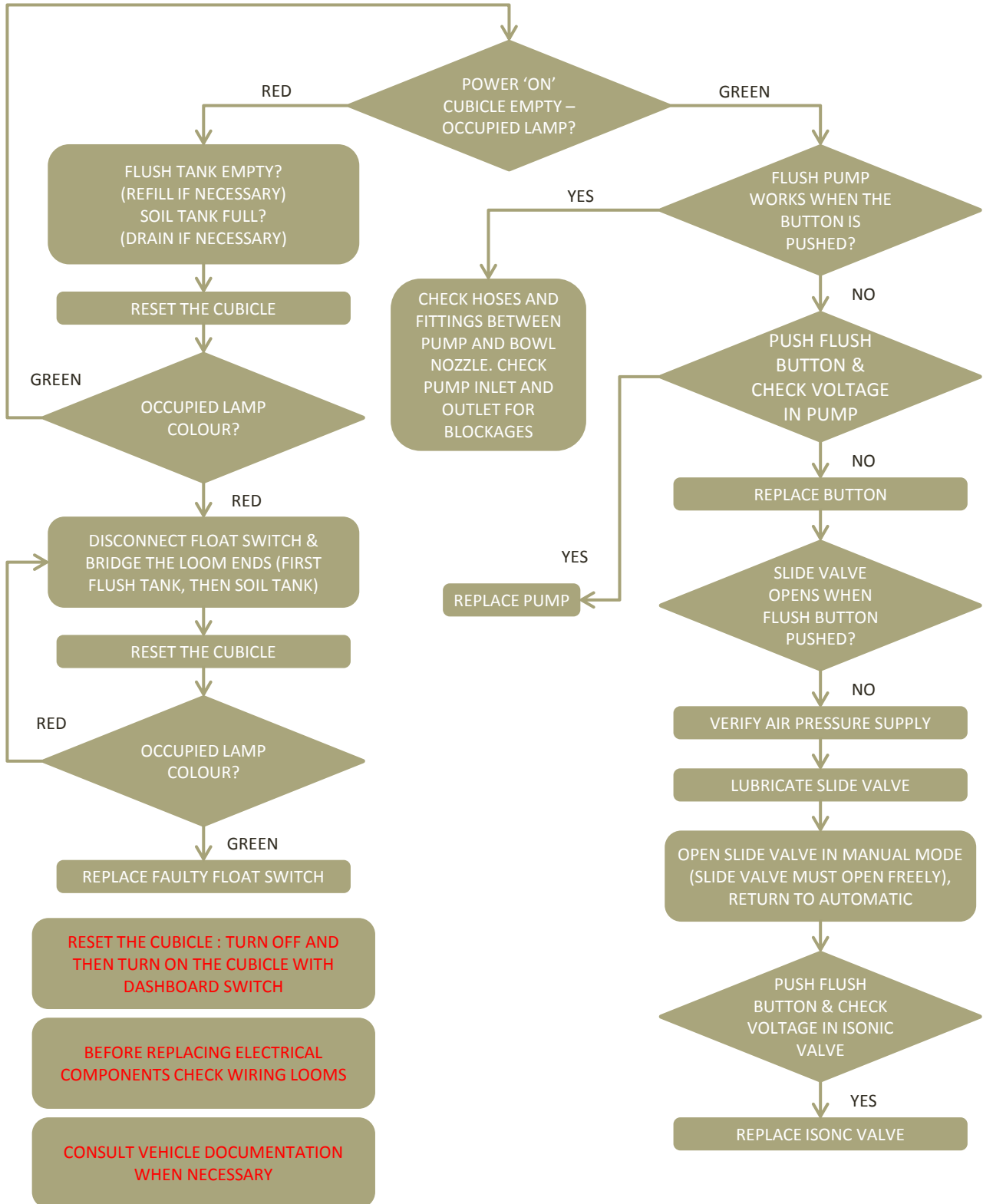

Fault Finding

- Interior Lamp Timer

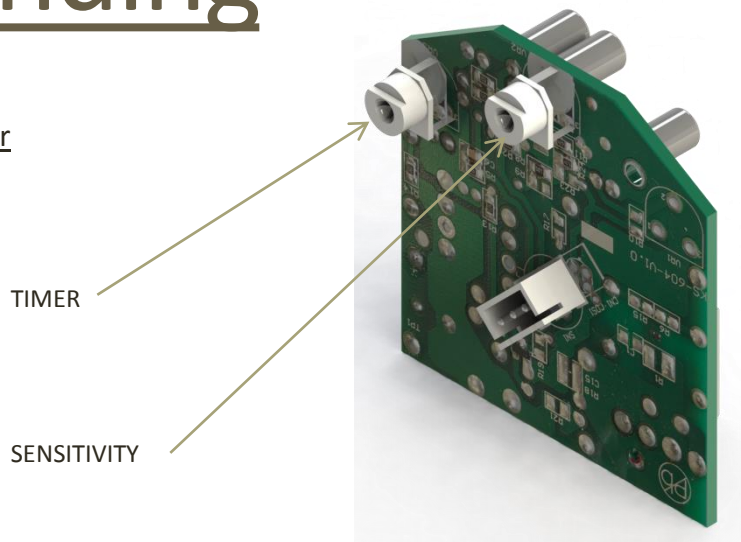

PIR SENSOR DETECTS HEAT AND MOVEMENT. THE TIME IS DETERMINED BY THE MULTIPLEX SYSTEM AND THE TIMER ADJUSTER MUST BE SET TO ITS LOWEST. CONSULT THE DEALER TO HAVE THIS ADJUSTED IF NECESSARY. THE SENSITIVITY CAN BE ADJUSTED ON THE UNIT AS SHOWN.

- Interior Lights Not Working

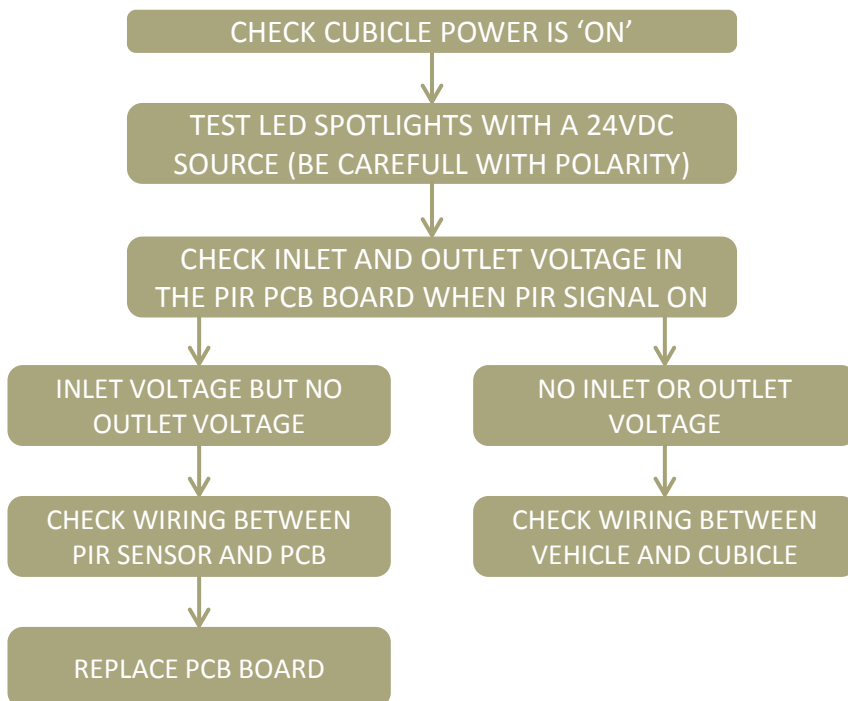

Service

- Hand drier (Vanity Pod)

Disconnect the power to the cubicle.

Remove 2x screws on the underside of the hand drier.

Remove the front cover of the hand drier.

Remove 2x Rubber hole covers.

Remove 3x screws, releasing the unit from the wall.

Disconnect the two cables passing through the out wall of the cubicle making sure they do not fall down the back.

Re-connect a new unit and screw to the wall.

Make sure the rubber hole covers are re-fitted and fit the cover securing with both screws.

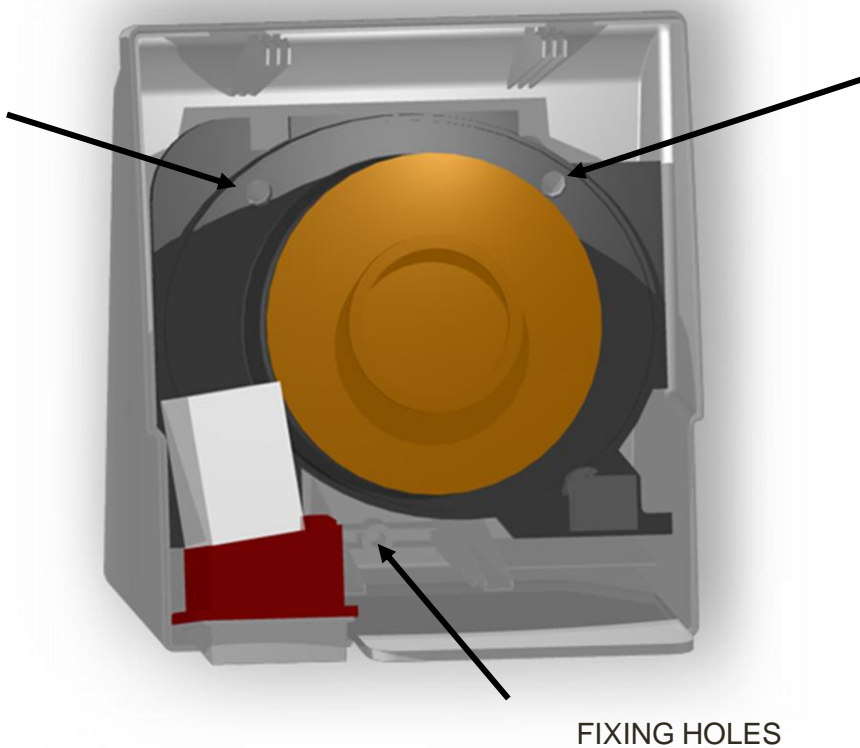

Service

- Hand wash & Flush buttons (Sink vanity)

Disconnect the power to the cubicle.

Unscrew the back nut on the reverse of the button.

Pull the button through mounting hole.

Remove terminals from the back of the button.

Connect terminals and re-fit button.



Use the two outer terminals

Service

- Hand wash/ Flush pumps

Disconnect the power to the cubicle

Remove any access panels protecting the tanks

Drain freshwater tank

Disconnect the wires to the pump

Remove from securing clip

Release inlet and outlet pipes.

Re-fit new pump. Make sure both inlet and outlet are water tight and the flow arrow is pointing in the correct direction.

Re-connect the power.

Close the drain on the supply tank.

Re-fill tank with freshwater.

Switch on power to cubicle.

Prime pump with 2-3 button pushes.

When working correctly, replace the insulation and cover

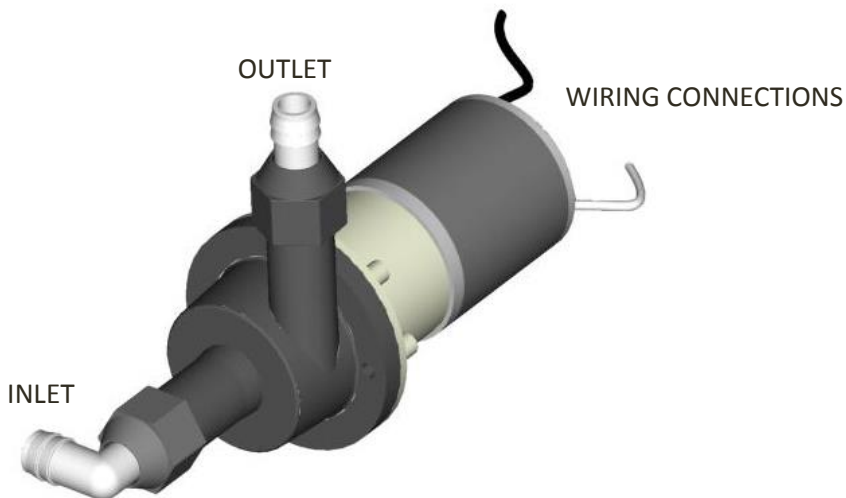

Service

- PCB

Remove GRP-cover.

Disconnect the power to the cubicle by removing the 2-way connector.

Remove all four remaining 9-way connectors.

Remove the 4x screws holding the PCB.

Fit the new PCB and attach the five connectors, making sure that the four 9-way connectors go back in the correct order.

- PIR Circuit Board

Remove the GRP-cover

Disconnect the power to the cubicle by removing the 2-way connector.

Remove all the wires in the screw terminals and the small sensor plug.

Remove the 2x screws holding the PCB.

Fit the new PCB and attach the small plug & wires, making sure that the wires go back in the correct order.

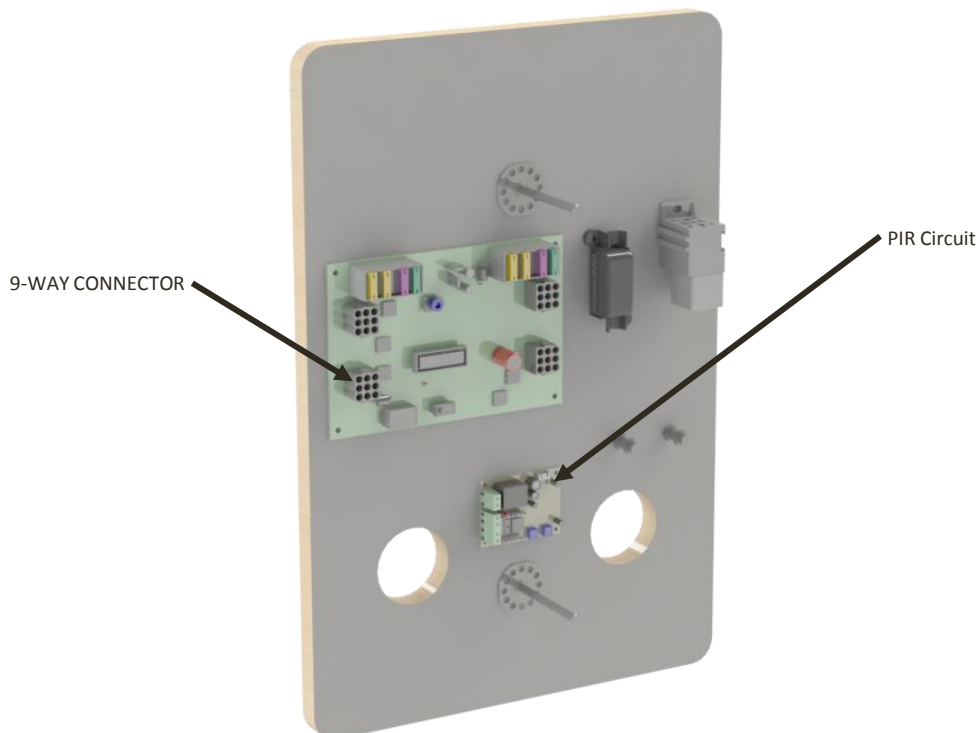

Service

- Toilet Slide Valve (Toilet Bowl)

Removal

Disconnect the power to the cubicle.

Remove 4x fixing screws from around the top of the bowl.

Pull and twist the bowl to release the seal from the soil tank.

Once released, remove the supply hose to the flush nozzle.

Lift bowl out and remove the 2x air supply hoses to the air cylinder.

Remove 4x fixing bolts, securing the slide valve to the toilet bowl.

CAUTION: As this air supply is from the vehicle (via the control valve), when it is disconnected the air pressure in the pipes will be at approx. 8 bar and will cause the pipe to 'snake around' violently if it is not held firmly.

Replacement

Position the valve assembly on the bottom of the bowl and secure with the 4x bolts. Tighten bolts to 6 kgf/cm² using a torque wrench

Smear silicone grease or similar around the black O-ring on the pneumatic valve and pass bowl through aperture on the cowling push firmly into the soil tank. Ensure that the rubber fin gasket is not in the entrance to the tank and on the bottom of the valve.

Reconnect the air pipes to the cylinder and the inlet pipe to the flush nozzle.

Connect the slide valve outlet to the routing pipe to soil tank.

Start the vehicle engine and switch on the WC master switch. Wait until the vehicle air pressure is at maximum before attempting to flush the toilet.

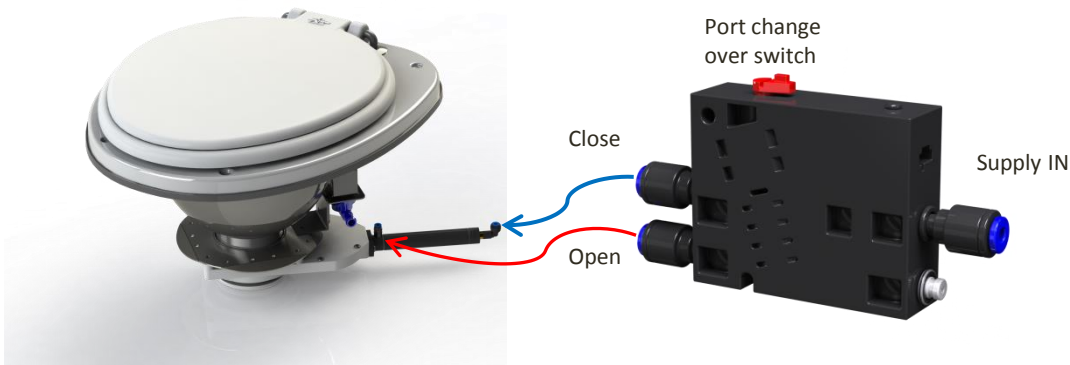

Service

- Toilet Valve Control Box (Behind Vanity Door)

Disconnect the power to the cubicle.

Unclip the black control valve from its location.

Remove the electrical connector from the valve.

Remove the 3x pipes from the valve.

Reconnect new valve making sure that the pipes are in the correct location.

CAUTION: As this air supply is from the vehicle (via the control valve), when it is disconnected the air pressure in the pipes will be at approx. 8 bar and will cause the pipe to 'snake around' violently if it is not held firmly.

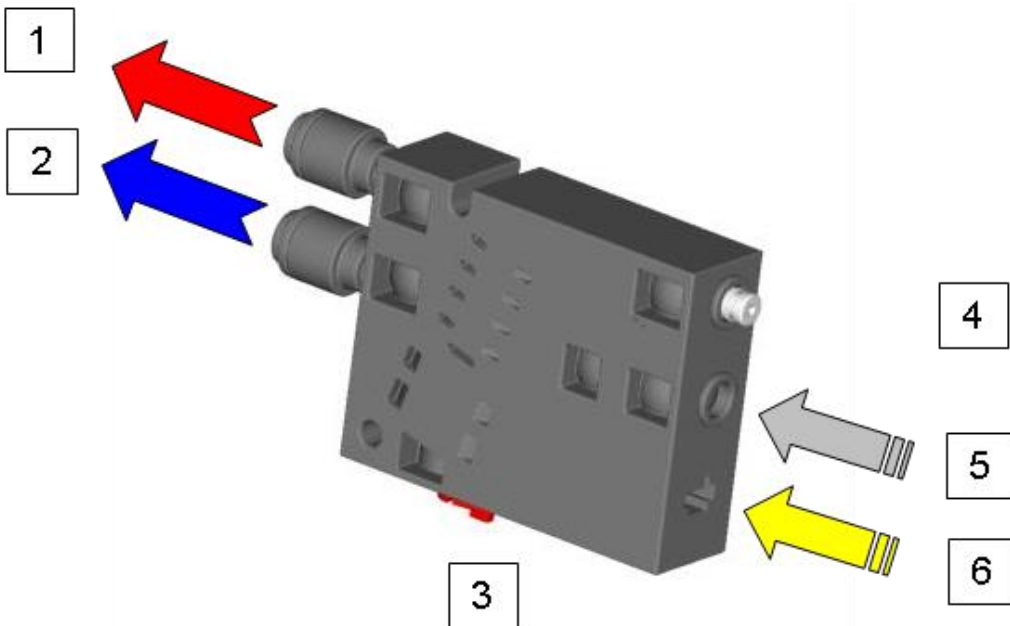

1. AIR SUPPLY OUT – TO FRONT OF CYLINDER TO OPEN SLIDE VALVE
2. AIR SUPPLY OUT – TO END OF CYLINDER TO CLOSE SLIDE VALVE
3. OVERRIDE SWITCH – SWAPS PORTS 1 & 2 OVER
4. EXHAUST – MUST BE KEPT CLEAR
5. AIR SUPPLY FROM VEHICLE – 10BAR MAX
6. ELECTRICAL CONNECTOR

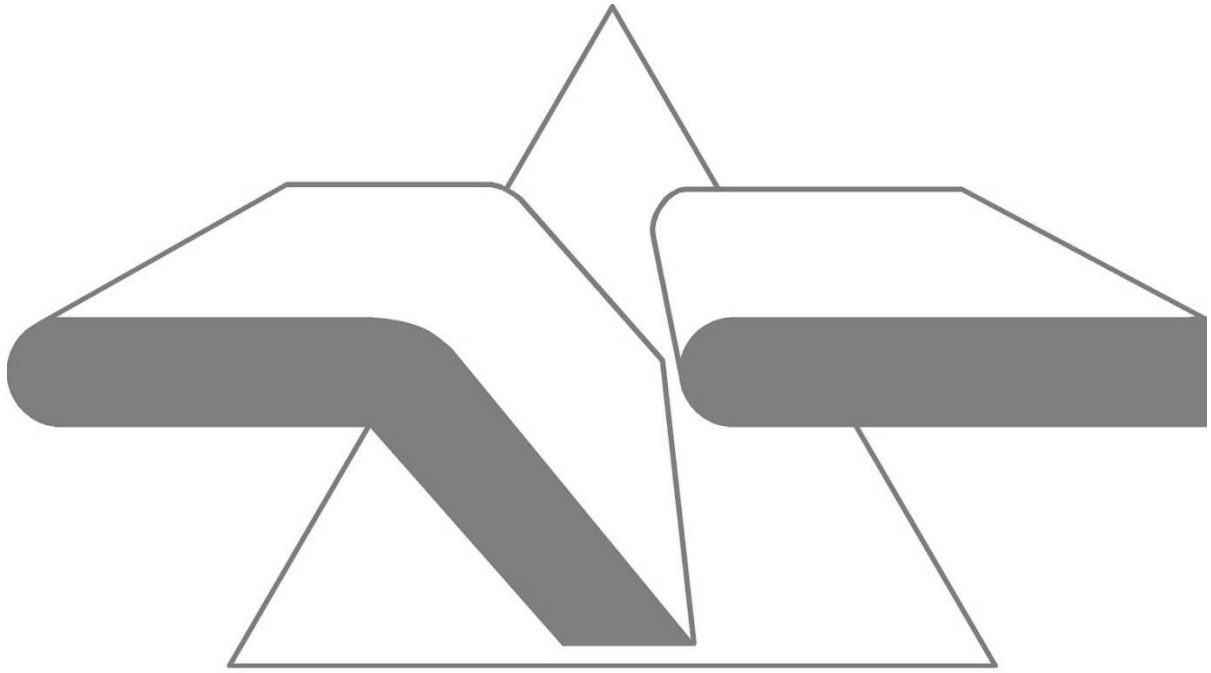

Shades Technics

www.shades-technics.com